

RaceMaster[™] **Instruction Manual**

The RaceMaster™ makes your contests Race more exciting!

Features...

- Durable packaging system allows for safe storage between races.
- 9 volt DC power pack.
- Complete installation and operating instructions included.
- Start switch, power receptacle, and reset switch located conveniently at the starter end of track.
- Flashing red light located in full view on back of the display for the starter.
- Large 5/8" high efficiency triple LED displays designed to be mobile, enabling maximized audience participation.
- All three connections are unique and can not be interchanged or attached improperly.
- The **RaceMaster™** is a high quality, easy to assemble tool.
- The unique packaging allows for complete testing of the system prior to race day. We recommend that you test The RaceMaster at least one week prior to the event.
- All integrated circuits are in sockets for ease of replacement.
- The **RaceMaster™** comes complete with a limited warranty.

Testing The RaceMaster™

1. Plug one end of power pack into jack on switch assembly and other end into wall outlet.
2. All displays should light up.
3. Press the "reset" button. All displays should return to 0.
4. Drop the start chute and the displays start running. The red light should begin to flash.
5. Go to the end of the track and pass your hand over all the sensors. One display should be flashing corresponding to the first sensor activated.
6. Reset the displays. The red light should turn off.
7. Reset the displays.
8. The **RaceMaster™** is now ready to go.

Installation Instructions

BASICS

- Do not attach the section of track which contains the finish line at this time.
- The sensor board connectors and harness should be installed on the right hand side of the track, as viewed from starter's position at the top of the track. From this position, the lanes are numbered from right to left (see drawing RM-01).
- The switch bracket with spring switch will be attached at the start of the track (see drawing RM-02).
- The ribbon cable allows the "bridge" to either straddle the track or sit sideways (parallel) to the track.
- The **RaceMaster™** is designed to function with the light from a normally lit room.

STEP BY STEP

1. At the finish line, drill a 7/16" hole completely through the track in the center of each of the 4 lane strips. Use the sensor board to mark the hole locations on the lane strips to verify that there is no variance to the on-center dimension of the guides. If the sensor is slightly off center to the lane strips, it is fine as long as the hole is in the lane strips and the sensor shows through as the car passes over.
2. Cut a notch to the width of the sensor, on the right side of the track, opposite the sensor holes (looking down the track from the starting line). This allows the sensor board to slide through the side of the track.

3. Turn the track over and lay the sensors in the drilled holes. Fasten with screws (furnished). Note — the sensor board will extend past the edge of the track on the right side.
4. Turn the track back over, being careful not to damage the extended sensor board. Attach the last section of track.
5. Uncoil the harness cable so that the bracket will be at the starter end.
6. Plug the “finish line display” and harness cables into the sensor board.

Note — each connector is unique and may be only plugged in one way.

7. Turn the “finish line display” so it may be viewed from the starter’s position at the top end of the track.
8. Plug the power pack into the AC outlet and its small plug into the cable jack on the start bracket at the end of the harness.
9. Press the “reset” button. Push down on the spring switch. The displays start counting. Pass your hand over the sensor holes and counting will stop.
10. Slide the start bracket back and forth under the starter’s end of the track so that the spring switch will be triggered properly by the starting bar. Drill two 3/16” holes from the bottom up. Bolt the bracket with the screws provided.
11. To dismantle, reverse the order of above items.

Troubleshooting

If one or more displays flash zeros

- The sensors are not receiving enough light. Position the track finish line under a ceiling light.
- The sensor board is delicate. If one of the sensors is damaged, the counter display will not operate.

If the harness connector won't come unhooked

- Press down on the ribbed tab before pulling the connector.

If the timer fails to start when the cars are tripped

- The reset button may not have been pushed.
- A wire may be loose in the starter bracket.
- The start switch may not have been tripped. To test, push the reset button and gently push down on the spring switch.

TESTING THE SENSORS

IMPORTANT ! - Do not begin the race until this procedure has been completed successfully.

Plug the power supply in to a wall outlet and the other end into the switch bracket.

The display will momentarily display "FOO HOO" , and then perminately show a "0" for each lane.

Hold the reset button down for no more then 3 seconds. The display should show the following on each lane;

L1L L2L etc.

**L= low H= high
the number is which lane
L means lane**

When you pass your hand or a car over the finish line sensor the last "L" should switch to "H" .This means the sensor is switching from low to high and is operating as designed.

Should any lane not switch please see the Trouble shooting section of these instructions.

Our light Accessory may be required. Please call.

Once this test has been succuessfully completed-Gentleman Start Your Engines !



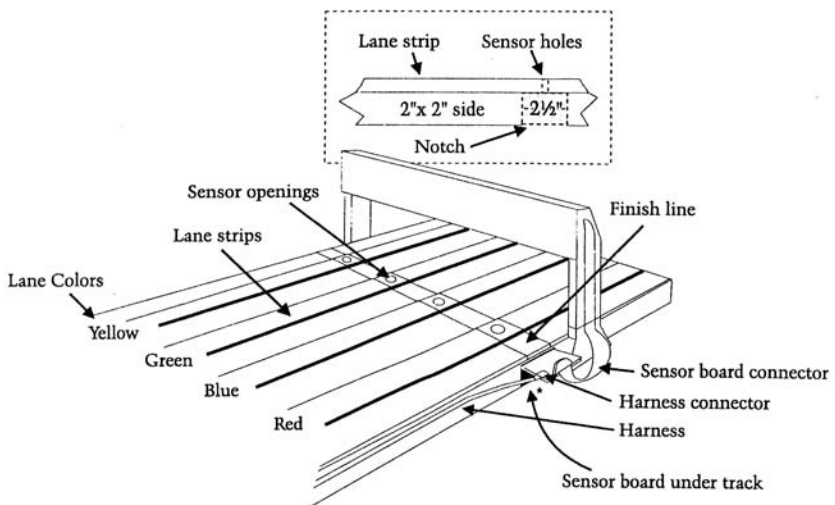

End of Track Sensor Installation

*For a box style track, cut a rectangular hole to slide the sensor board through.

RM-01

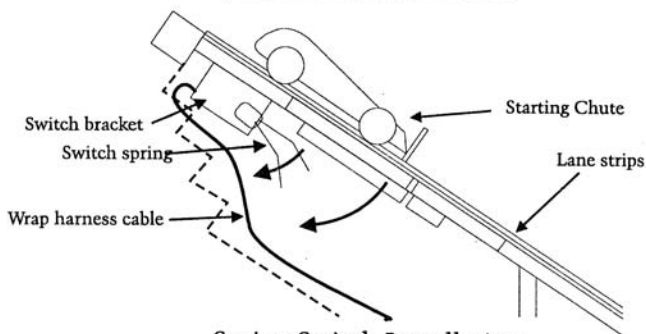

Spring Switch Installation

- ① Slide bracket back and forth so the switch spring clicks at the precise moment the car begins to roll.
- ② Switch spring lever may need to be bent to fit.
- ③ Fasten the wrap harness cable away from the trip mechanism.
- ④ Align the switch bracket under the center of one of the lane strips, while also adjusting its location as in instruction ①. Mark and drill holes from the bottom to ensure accuracy.

RM-02

Best Track Attachment

Start Bracket

START END VIEW

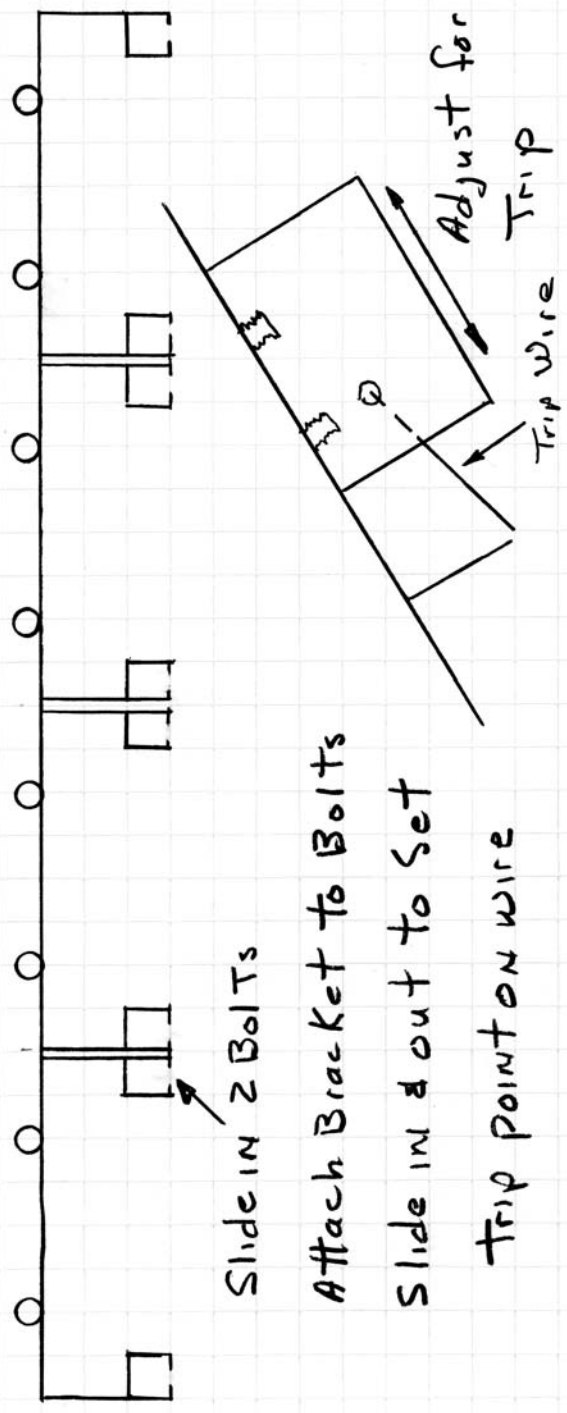

Slide in 2 Bolts

Attach Bracket to Bolts

Slide in & out to Set

Trip Point on wire

Sensor Board Attachment

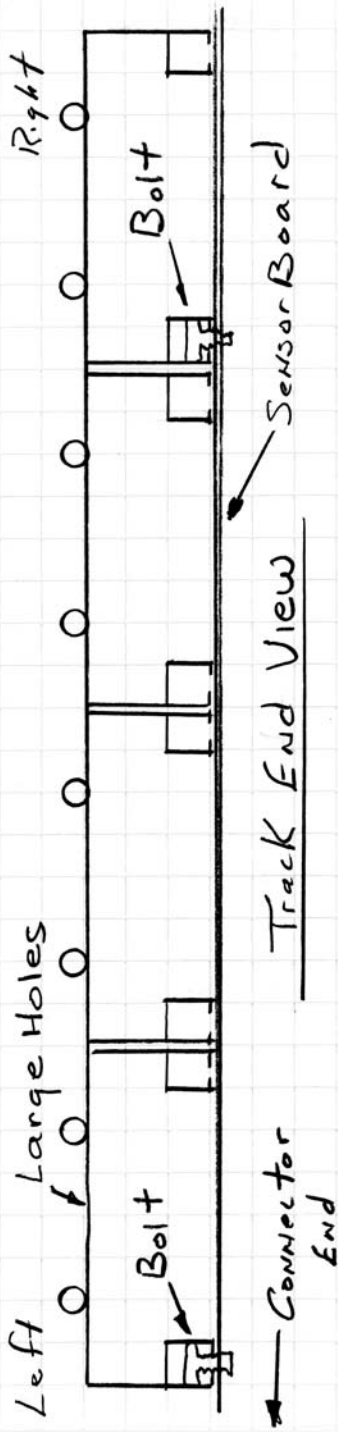

Slide in 2 Bolts as shown
Line Sensors under large holes
Fasten with Wingnuts

**DISREGARD IF VISTA OR USB ONLY COMPUTER IS USED.
OUR ACCESSORY COM1/USB IS REQUIRED.**

COMPUTER MONITORING OF THE RACEMASTER

Equipment Required:

Laptop or other computer with Windows xp only with com1 port
RS-232 male/female computer cable, 9 pin

Setting the computer to hyper terminal status

Attach the cable to the RACEMASTER RS-232 connector located on
the Sensor board and serial port on your computer.

Donot power up the RACEMASTER

Turn on the computer

SELECT:

Start
Programs
Accessories
Communications
Hyper terminal
Type/name RACEMASTER
Go to connect using
Direct to COM 1

Click OK

Select the following:

bits per second-9600
Data bits-8
Parity bits-none
Stop bits-1
Flow control-select none

Click OK

Plug in the power connection on the RACEMASTER

IMPORTANT!-Turn on caps lock now

The following display should now be on your screen:

JIT,INC. RACEMASTER Software Copyright January 2002

Software version 0.0 Hardware version 0.0

Serial Port Functions:

D - Display Zero Page Memory
V - Display Version And Help (returns to this menu)
L - Report Finish Line Results
T - Perform Display Text ,All Pixels Enabled
O - Display Lane Order and State. Led Indicates Start
Switch State
Q - Display Rotating Character Display Test
R - Restart Timing Sequence
F - Flash LED
S - Start Timing Sequence

Version 1.0
January,2002

TROUBLE SHOOTING

The display must be reset before each race.

The Racemaster will not function outside due to the Sun's radiation.

When performing the "Sensor Test" rotating letters and numbers appear.

answ. The reset button was held in for longer than three seconds.

We do not have a computer, is it necessary?

answ. The computer connector is an accessory and not required.

We have a plastic or metal track, how do we fasten the sensor board to the track?

answ. Use velcro strips furnished.

On the display, two lanes are flashing.

answ. A tie to 5,000 of a second has occurred! When using the computer it will show times to 10,000 of a second.

The harness connector will not come loose

answ. Press down on the ribbed tab before pulling connector.

For answers to product questions or to report a problem,
please call

Tony Wieda at (309) 242-6255

Email: tony@interactmt.com



Limited Warranty

IMT, LLC (collectively referred to as "the warrantor") will repair this product with new or refurbished parts, without charge, in the U.S.A. This warranty is guaranteed for the life of the warrantor, as long as he is capable, from the date of original purchase. Covered repairs are limited to defects in material or workmanship.

This warranty is extended only to the original purchaser. A receipt or other proof of purchase is required prior to performance of warranted repairs.

This warranty only covers failures due to defects in material which occur within normal use and care. It does not cover damage which occurs in shipment or failures which are caused by products not supplied by the warrantor. Nor does it cover failures which result from accident, misuse, abuse, neglect, mishandling, misapplication, alteration, faulty installation, modification, or service by anyone other than the warrantor.

LIMITS AND EXCLUSIONS

There are no express warranties except as listed above.

The warrantor shall not be liable for special, incidental, consequential, or punitive damages, including (without limitation) loss of goodwill, profits or revenue, loss of use of this product or any associated equipment, cost of substitute equipment, downtime costs, or claims of any party dealing with buyer for such damages, resulting from the use of this product or arising from breach of warranty or contract, negligence, or any other legal theory.

The warranties of merchantability and fitness for a particular purpose are limited to one year from the date of purchase.